

# EE 435

## Lecture 9:

### Folded-Cascode Amplifiers Current Mirror Op Amps

Where we are at:

# Basic Op Amp Design

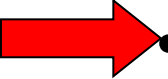
- Fundamental Amplifier Design Issues
- Single-Stage Low Gain Op Amps
-  • Single-Stage High Gain Op Amps
- Other Basic Gain Enhancement Approaches
- Two-Stage Op Amp

## Review from Last Lecture

Are there other useful high output impedance circuits that can be used for the quarter circuit?

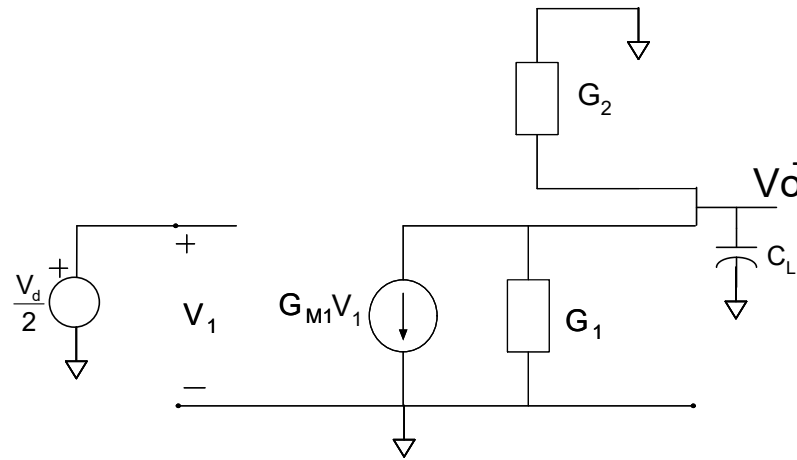

$$A_{V0} = \frac{-G_{M1}}{2(G_1 + G_2)}$$

$$BW = \frac{G_1 + G_2}{C_L}$$

$$GB = \frac{G_{M1}}{2C_L}$$

## Review from Last Lecture

# Implementation of Biased Folded Cascode Amplifier?

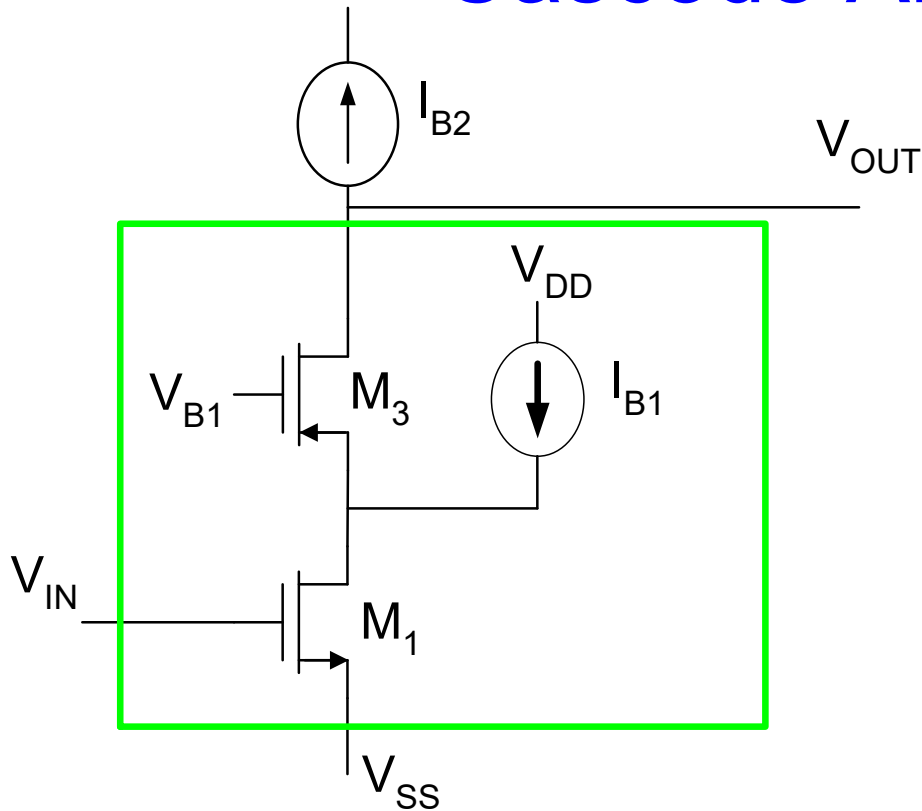

**Biased Folded Cascode**

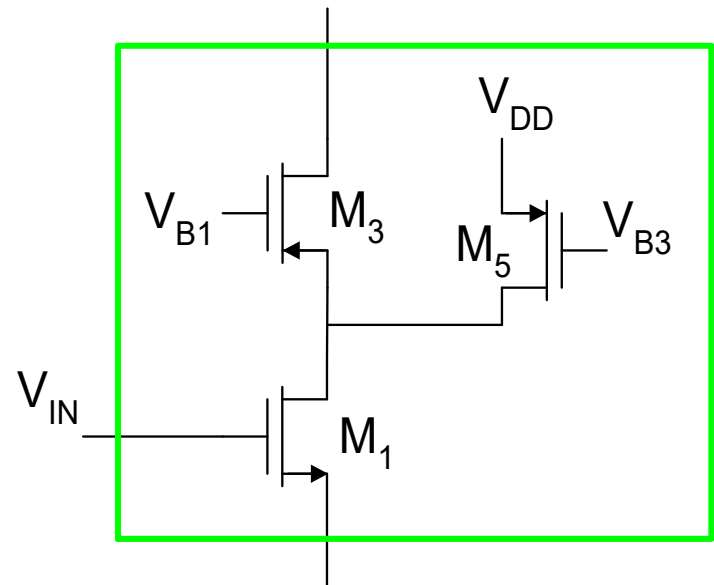

**Implementation of Biased Folded Cascode**

# Review from Last Lecture

## Basic Amplifier Structure Comparisons

Practical Parameter Domain		
Common Source	$A_{VO} = \left( \frac{2}{\lambda} \right) \left( \frac{1}{V_{EB}} \right)$	$GB = \left( \frac{2P}{V_{DD} C_L} \right) \left( \frac{1}{V_{EB}} \right)$
Cascode	$A_{VO} = \left( \frac{4}{\lambda_1 \lambda_3} \right) \left( \frac{1}{V_{EB1} V_{EB3}} \right)$	$GB = \left( \frac{2P}{V_{DD} C_L} \right) \left( \frac{1}{V_{EB1}} \right)$
Regulated Cascode $\Theta$ =pct power in A	$A_{VO} \approx \left( \frac{4}{\lambda_1 \lambda_3} \right) \left( \frac{A}{V_{EB1} V_{EB3}} \right)$	$GB = \left( \frac{2P}{V_{DD} C_L} \right) \left( \frac{(1-\Theta)}{V_{EB1}} \right)$
Folded Cascode $\Theta$ =fraction of current of $M_5$ that is in $M_1$	$A_{VO} \approx \left( \frac{4\Theta}{(\Theta\lambda_1 + \lambda_5)\lambda_3 V_{EB1} V_{EB3}} \right)$	$GB = \left( \frac{2P}{V_{DD} C_L} \right) \left[ \frac{\Theta}{V_{EB1}} \right]$

# Review from Last Lecture Folded-Cascode Operational Amplifier

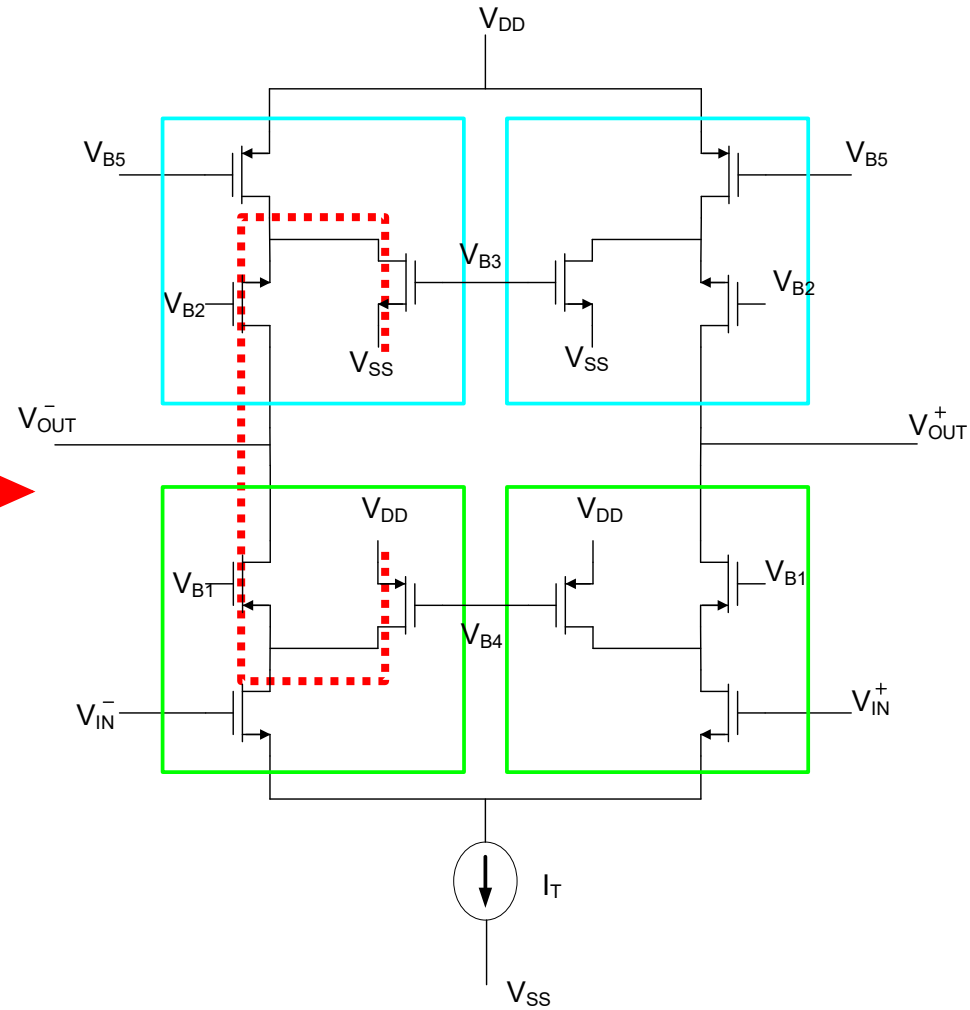
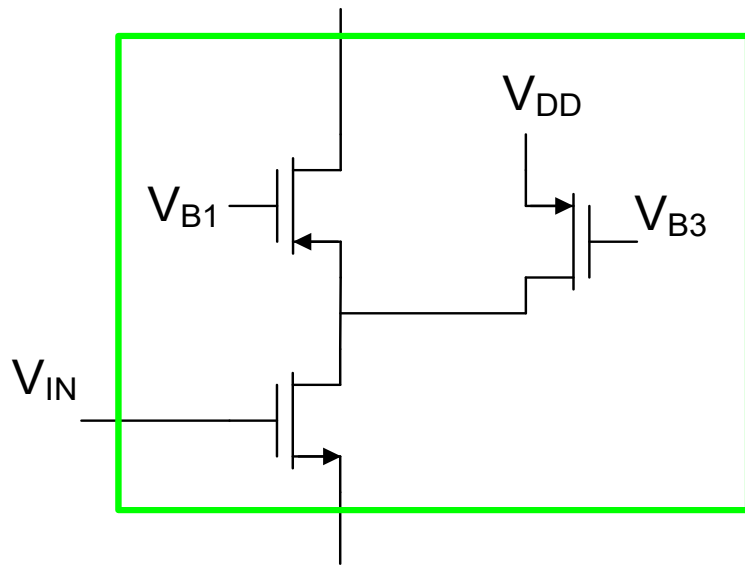

QUARTER CIRCUIT

Op Amp

# Review from Last Lecture

## Folded Cascode Op Amp

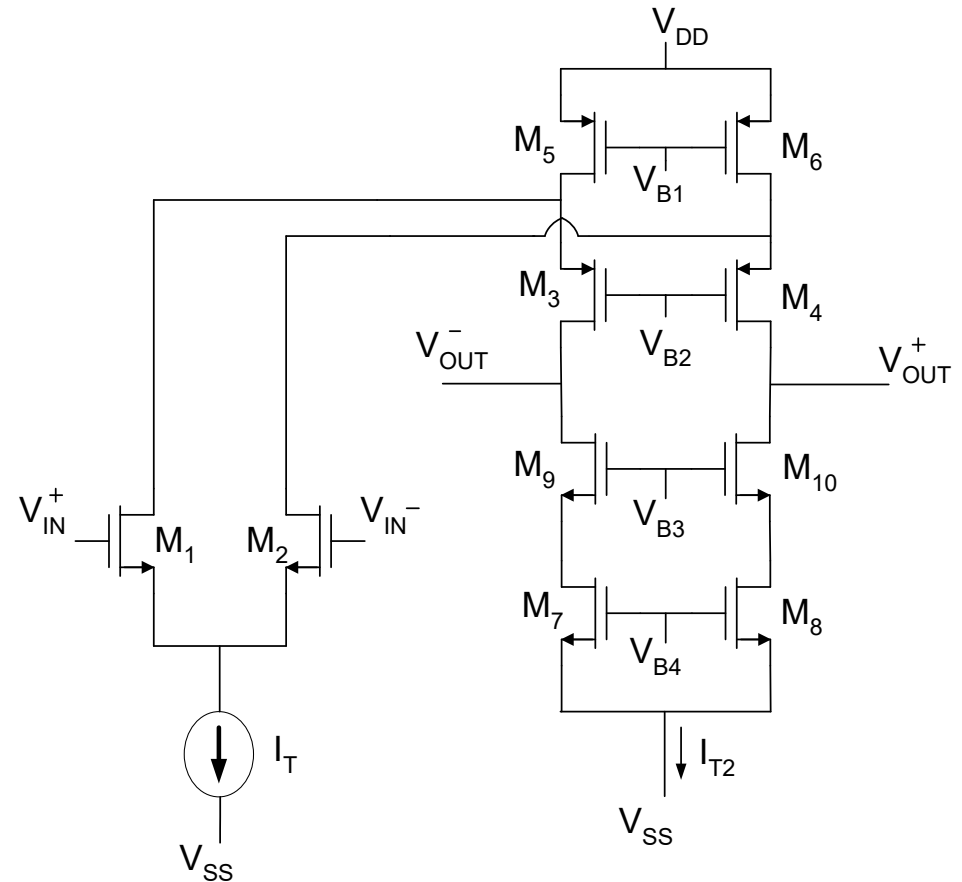

- Needs CMFB Circuit for  $V_{B4}$
- Either single-ended or differential outputs
- Can connect counterpart as current mirror to eliminate CMFB
- Folding caused modest deterioration of  $A_{v0}$  and GB energy efficiency
- Modest improvement in output swing

# Review from Last Lecture

## Operational Amplifier Structure Comparison

Practical Parameter Domain – Single-ended output expressions: Need CMFB			
Reference Op Amp	$A_{V0} = \left[ \frac{1}{\lambda_1 + \lambda_3} \right] \left( \frac{1}{V_{EB1}} \right)$	$GB = \left( \frac{P}{2V_{DD}C_L} \right) \cdot \left[ \frac{1}{V_{EB1}} \right]$	$SR = \frac{P}{2V_{DD}C_L}$
Telescopic Cascode	$A_{V0} = \frac{2}{V_{EB1}(\lambda_1\lambda_3V_{EB3} + \lambda_5\lambda_7V_{EB5})}$	$GB = \left( \frac{P}{2V_{DD}C_L} \right) \cdot \left[ \frac{1}{V_{EB1}} \right]$	$SR = \frac{P}{2V_{DD}C_L}$
Regulated Cascode $\Theta$ =pct power in A	$A_{V0} \approx \frac{2}{V_{EB1} \left( \frac{\lambda_1\lambda_3V_{EB3}}{A_1} + \frac{\lambda_5\lambda_7V_{EB7}}{A_3} \right)}$	$GB = \left( \frac{P(1-\Theta)}{2V_{DD}C_L} \right) \cdot \left[ \frac{1}{V_{EB1}} \right]$	$SR = \frac{P(1-\Theta)}{2V_{DD}C_L}$
Folded Cascode $\Theta$ =fraction of current of $M_5$ that is in $M_1$	$A_{V0} = \frac{2\Theta}{V_{EB1}((\Theta\lambda_1 + \lambda_5)\lambda_3V_{EB3} + (1-\Theta)\lambda_9\lambda_7V_{EB9})}$	$GB = \left( \frac{P}{2V_{DD}C_L} \right) \cdot \left[ \frac{\Theta}{V_{EB1}} \right]$	$SR = \frac{\Theta P}{2V_{DD}C_L}$



# Review from Last Lecture

## Folded Cascode Op Amp (Single-ended Output)

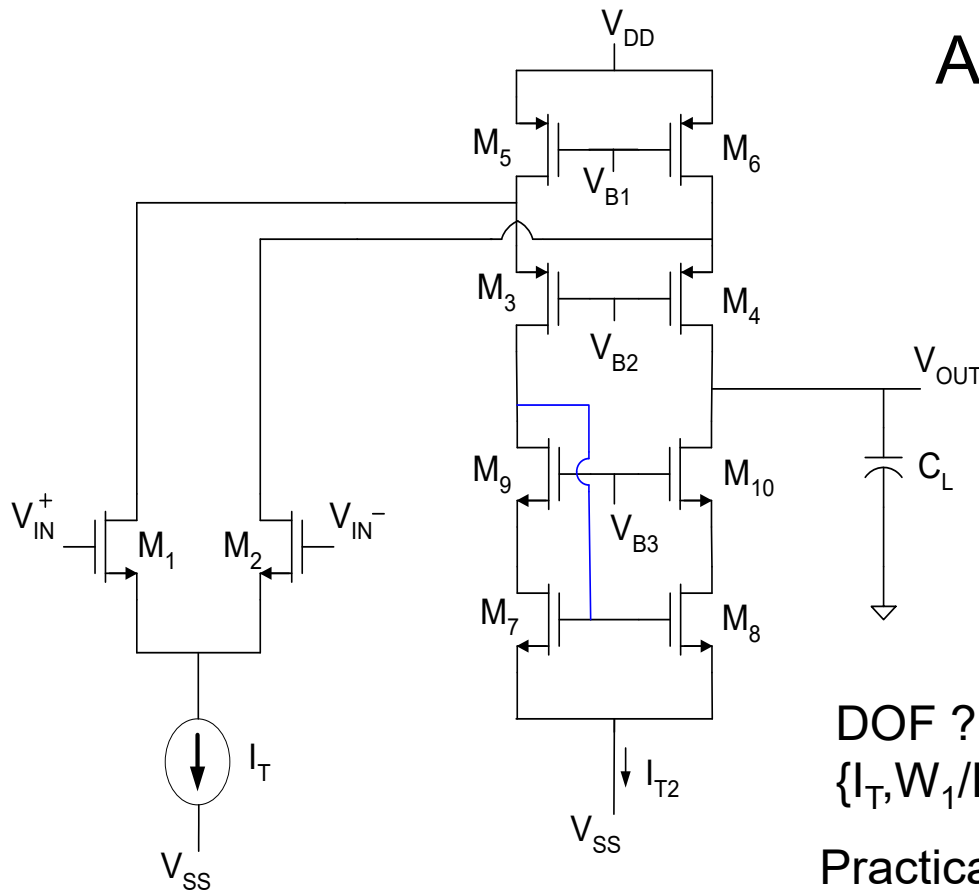

$$A_{v0} \approx \frac{g_{m1}}{(g_{o1} + g_{o5}) \frac{g_{o3}}{g_{m3}} + (g_{o7}) \frac{g_{o9}}{g_{m9}}}$$

$$GB = \frac{g_{m1}}{C_L}$$

How many degrees of freedom are there?

What is a practical design parameter set?

DOF ? **9 DOF**

$\{I_T, W_1/L_1, W_5/L_5, W_3/L_3, W_9/L_9, W_7/L_7, V_{B1}, V_{B2}, V_{B3}\}$

Practical Design Parameters

$\{P, \theta, V_{EB1}, V_{EB3}, V_{EB5}, V_{EB7}, V_{EB9}, V_{B2}, V_{B3}\}$

where  $\theta = I_T / (I_T + I_{T2})$

# Folded Gain-boosted Cascode Amplifier

$$A_o \approx \frac{-g_{m1}}{(g_{o1}) \frac{g_{o3}}{A g_{m3}}}$$

$$GB = \frac{g_{m1}}{2C_L}$$

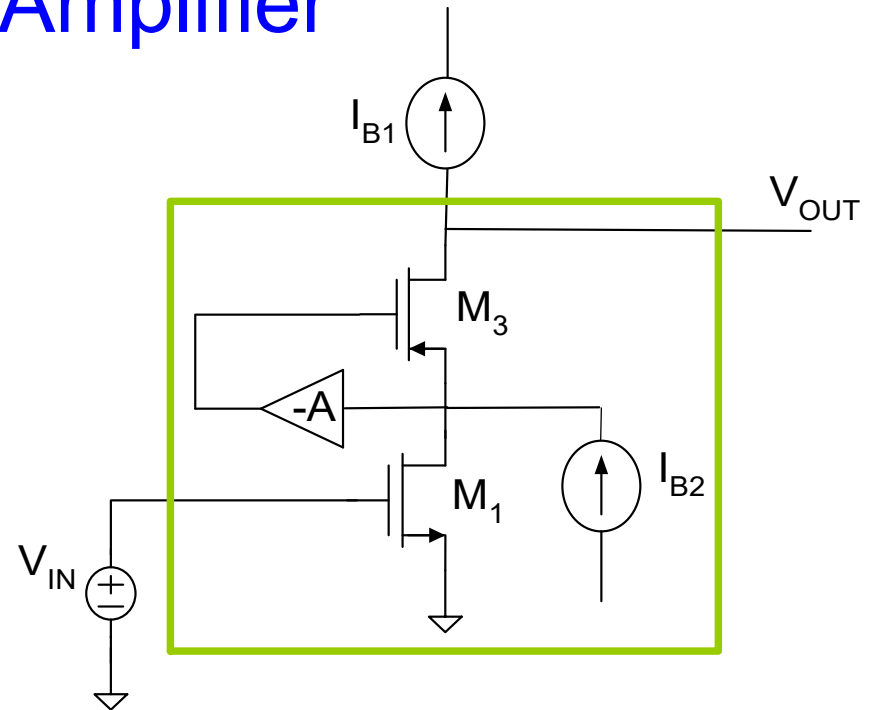

- with ideal current source bias
- modest improvement in output swing

# Folded Gain-boosted Cascode Amplifier

$$\frac{V_{OUT}}{V_{IN}} \approx \frac{-g_{m1}}{sC_L + \frac{(g_{o1} + g_{o5})g_{o3}}{g_{m3}A}}$$

$$A_0 \approx \frac{-g_{m1}g_{m3}A}{(g_{o1} + g_{o5})g_{o3}}$$

$$GB = \frac{g_{m1}}{C_L}$$

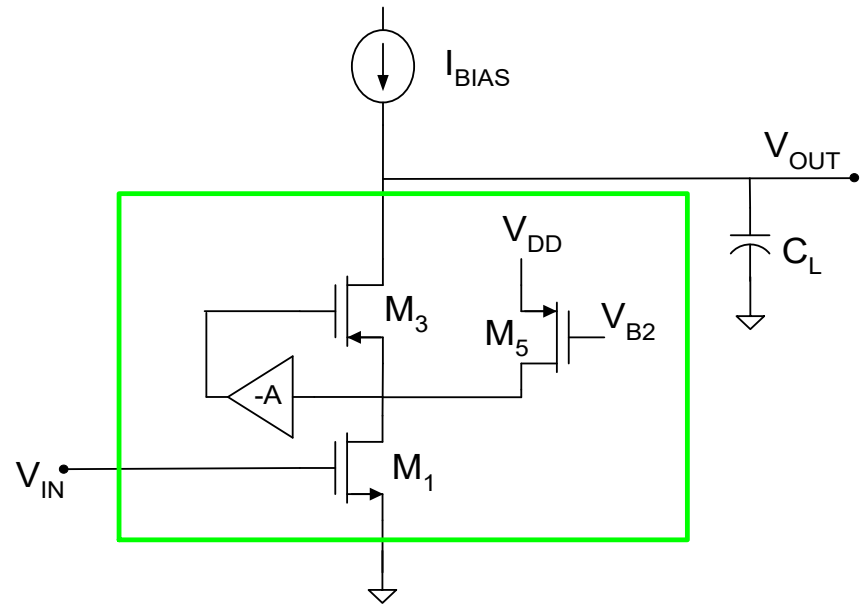

modest improvement in output swing

# Basic Amplifier Structure Comparisons

Small Signal Parameter Domain		
Common Source	$A_{VO} = \frac{g_m}{g_o}$	$GB = \frac{g_m}{C_L}$
Cascode	$A_{VO} = \frac{g_{m1} g_{m3}}{g_{o1} g_{o3}}$	$GB = \frac{g_{m1}}{C_L}$
Regulated Cascode	$A_{VO} \approx \frac{g_{m1} g_{m3}}{g_{o1} g_{o3}} A$	$GB = \frac{g_{m1}}{C_L}$
Folded Cascode	$A_{VO} = \frac{g_{m1}}{(g_{o1} + g_{o5})} \frac{g_{m3}}{g_{o3}}$	$GB = \frac{g_{m1}}{C_L}$
Folded Regulated Cascode	$A_{VO} = \frac{g_{m1}}{(g_{o1} + g_{o5})} \frac{g_{m3}}{g_{o3}} A$	$GB = \frac{g_{m1}}{C_L}$

# Basic Amplifier Structure Comparisons

## Practical Parameter Domain

Common Source	$A_{VO} = \left( \frac{2}{\lambda} \right) \left( \frac{1}{V_{EB}} \right)$	$GB = \left( \frac{2P}{V_{DD} C_L} \right) \left( \frac{1}{V_{EB}} \right)$
Cascode	$A_{VO} = \left( \frac{4}{\lambda_1 \lambda_3} \right) \left( \frac{1}{V_{EB1} V_{EB3}} \right)$	$GB = \left( \frac{2P}{V_{DD} C_L} \right) \left( \frac{1}{V_{EB1}} \right)$
Regulated Cascode $\Theta$ =pct power in A	$A_{VO} \approx \left( \frac{4}{\lambda_1 \lambda_3} \right) \left( \frac{A}{V_{EB1} V_{EB3}} \right)$	$GB = \left( \frac{2P}{V_{DD} C_L} \right) \left( \frac{(1-\Theta)}{V_{EB1}} \right)$
Folded Cascode $\Theta$ =fraction of current of $M_5$ that is in $M_1$	$A_{VO} \approx \left( \frac{4\Theta}{(\Theta\lambda_1 + \lambda_5)\lambda_3 V_{EB1} V_{EB3}} \right)$	$GB = \left( \frac{2P}{V_{DD} C_L} \right) \left[ \frac{\Theta}{V_{EB1}} \right]$
Folded Regulated Cascode $\Theta_1$ =pct of total power in A $\Theta_2$ =fraction of current of $M_5$ that is in $M_1$	$A_{VO} \approx \left( \frac{A4\Theta_2}{(\Theta_2\lambda_1 + \lambda_5)\lambda_3 V_{EB1} V_{EB3}} \right)$	$GB = \left( \frac{2P}{V_{DD} C_L} \right) \left( \frac{\Theta_2(1-\Theta_1)}{V_{EB1}} \right)$

# Folded Gain-boosted Telescopic Cascode Op Amp

$$A_o \approx \frac{-\frac{g_{m1}}{2}}{(g_{o1} + g_{o5}) \frac{g_{o3}}{A_3 g_{m3}} + g_{o7} \frac{g_{o9}}{A_1 g_{m9}}}$$

$$GB = \frac{g_{m1}}{2C_L}$$

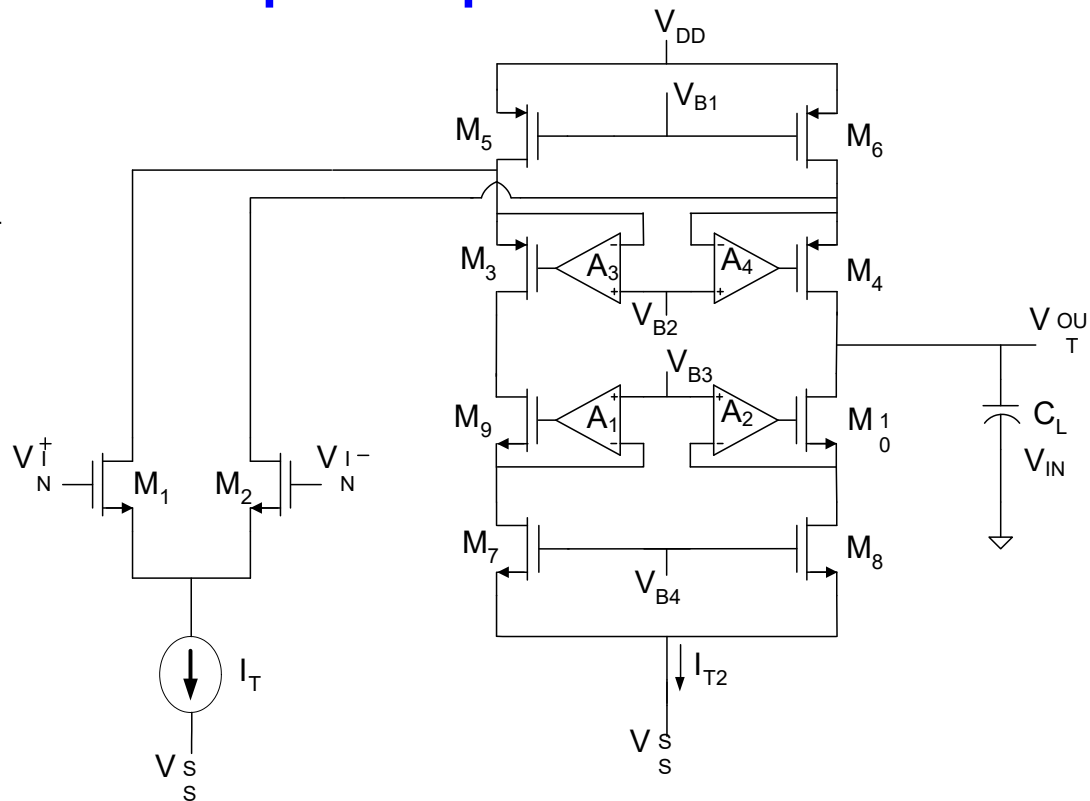

- Needs CMFB Circuit for  $V_{B4}$
- Either single-ended or differential outputs
- Can connect counterpart as current mirror to eliminate CMFB
- Folding caused modest deterioration in GB efficiency and gain
- Modest improvement in output swing

# Operational Amplifier Structure Comparison

Small Signal Parameter Domain: Single-ended Output, Need CMFB			
Reference Op Amp	$A_{vo} = \frac{1}{2} \frac{g_{m1}}{g_{o1} + g_{o3}}$	$GB = \frac{g_{m1}}{2C_L}$	$SR = \frac{I_T}{2C_L}$
Telescopic Cascode	$A_o = \frac{\frac{g_{m1}}{2}}{g_{o1} \frac{g_{o3}}{g_{m3}} + g_{o7} \frac{g_{o5}}{g_{m5}}}$	$GB = \frac{g_{m1}}{2C_L}$	$SR = \frac{I_T}{2C_L}$
Regulated Cascode	$A_o \approx \frac{\frac{g_{m1}}{2}}{g_{o1} \frac{g_{o3}}{g_{m3} A_1} + g_{o7} \frac{g_{o9}}{g_{m9} A_3}}$	$GB = \frac{g_{m1}}{2C_L}$	$SR = \frac{I_T}{2C_L}$
Folded Cascode	$A_o = \frac{\frac{g_{m1}}{2}}{(g_{o1} + g_{o5}) \frac{g_{o3}}{g_{m3}} + g_{o7} \frac{g_{o9}}{g_{m9}}}$	$GB = \frac{g_{m1}}{2C_L}$	$SR = \frac{I_T}{2C_L}$
Folded Regulated Cascode	$A_o = \frac{\frac{g_{m1}}{2}}{(g_{o1} + g_{o5}) \frac{g_{o3}}{g_{m3} A_3} + g_{o7} \frac{g_{o9}}{g_{m9} A_9}}$	$GB = \frac{g_{m1}}{2C_L}$	$SR = \frac{I_T}{2C_L}$

# Summary of Folded Amplifier Performance

- + Modest improvement in output signal swing (from  $5 V_{DS SAT}$  to  $4V_{DS SAT}$ )
- + Can directly feed output back to input to create buffer
- - Deterioration in  $A_{V0}$  (maybe 30% or more)
- - Deterioration in GB power efficiency (can be significant)
- - Minor increase in circuit size



# Other Methods of Gain Enhancement

Recall:

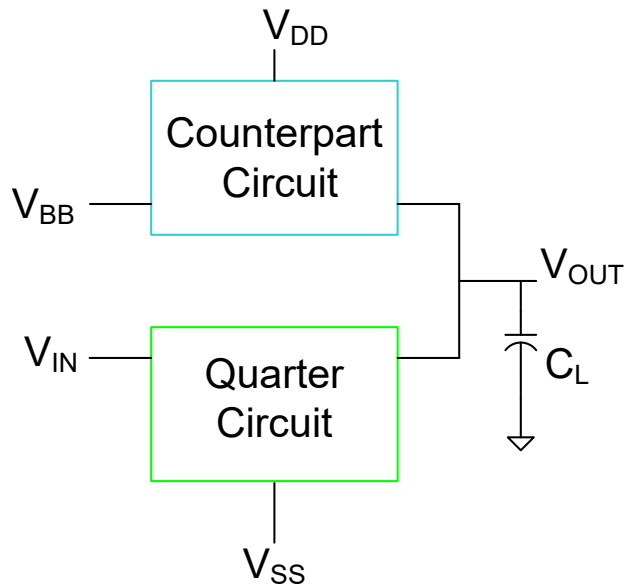

$$A_{V0} = \frac{-g_{mQC}}{g_{oQC} + g_{oCC}}$$

$$GB = \frac{g_{mQC}}{C_L}$$

Two Strategies:

1. Decrease denominator of  $A_{V0}$
2. Increase numerator of  $A_{V0}$

Previous approaches focused on decreasing denominator

**Consider now increasing numerator**

# Determination of op amp characteristics from quarter circuit characteristics

Small signal Quarter Circuit

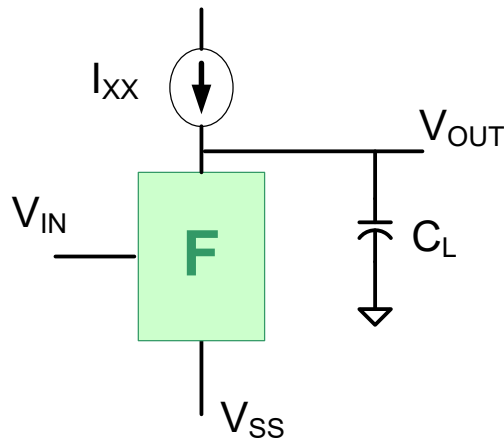

$$A_{VQC}(s) = \frac{-G_M}{sC_L + G}$$



Small signal differential amplifier

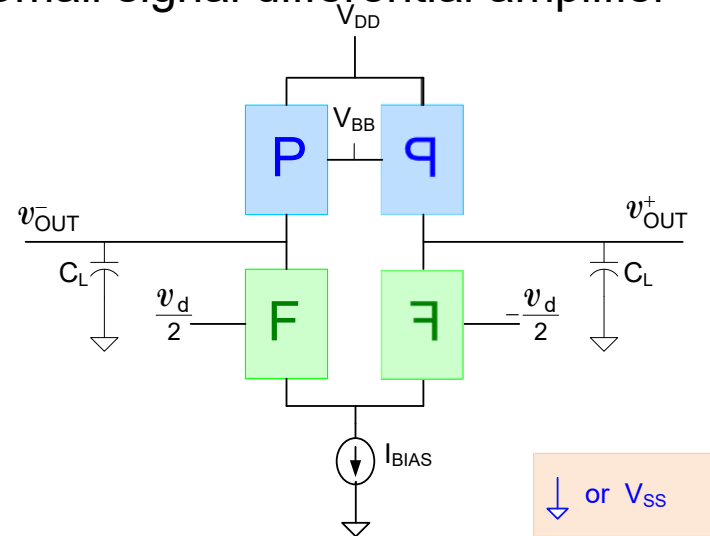

$$A_V = \frac{V_{O^-}}{V_d} = \frac{-G_{M1}}{sC_L + G_1 + G_2}$$

- Note that the counterpart circuit is simply serving as the biasing current source
- Could use counterpart circuits (or other circuits) from other quarter circuits for “P”
- Counterpart circuits connected as one-port
- Can think of making differential op amp directly from quarter circuit

# Differential input op amp directly from quarter circuit

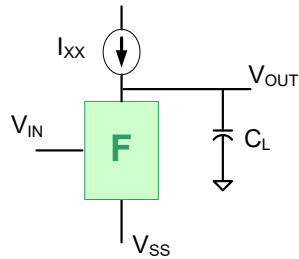

$$A_{VQC}(s) = \frac{-G_M}{sC_L + G}$$

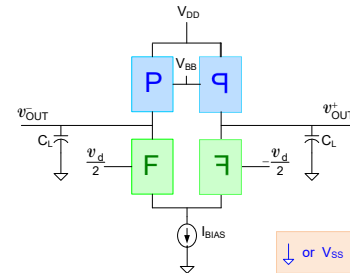

$$A_V = \frac{V_{O^-}}{V_d} = \frac{-\frac{G_{M1}}{2}}{sC_L + G_1 + G_2}$$

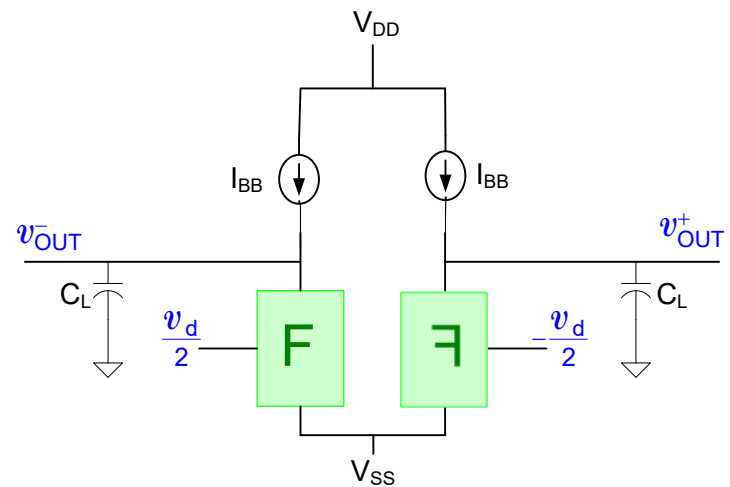
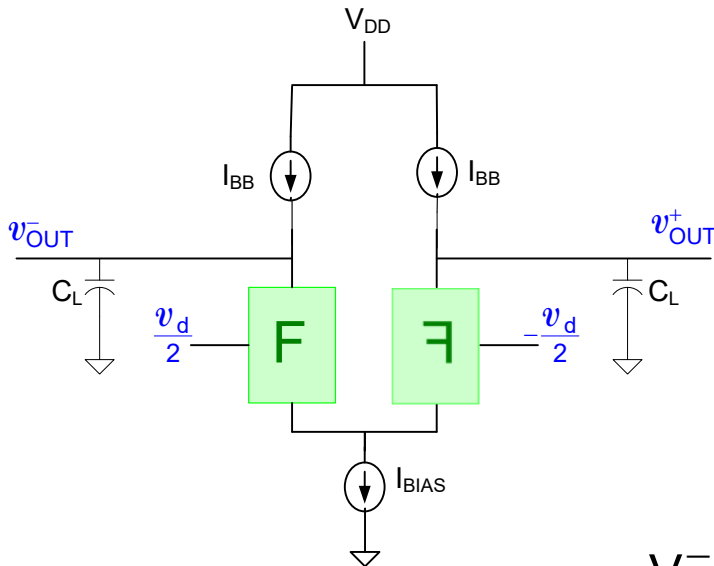

$$A_V = \frac{V_{O^-}}{V_d} = \frac{-\frac{G_{M1}}{2}}{sC_L + G_1 + G_{I_{BB}}}$$

$G_{I_{BB}}$  is the output conductance of  $I_{BB}$

# Alternative insight into what is happening

Can think of this as “steering” signal-dependent current to the output node which drives the total output conductance on the output node to obtain a signal-dependent output voltage

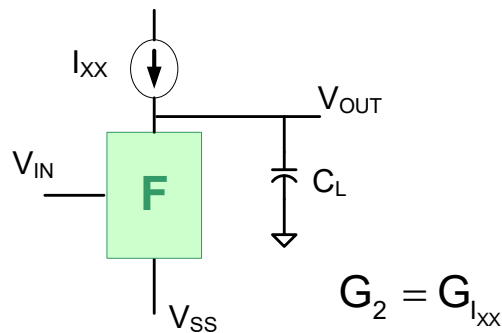

$$A_V(s) = \frac{-G_M}{sC_L + G_1 + G_2}$$

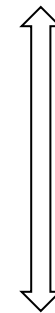
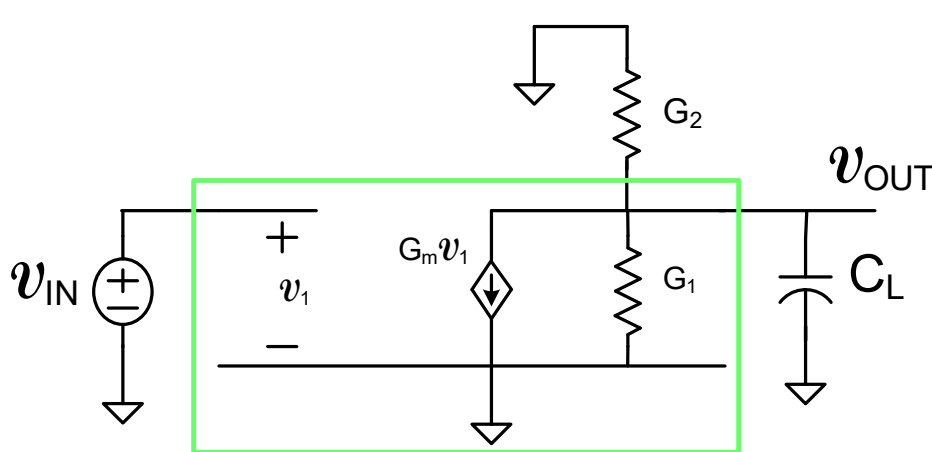

$$v_{OUT} (G_1 + G_2 + sC_L) + G_M v_{IN} = 0$$

# $g_{mEQ}$ Gain Enhancement Strategy

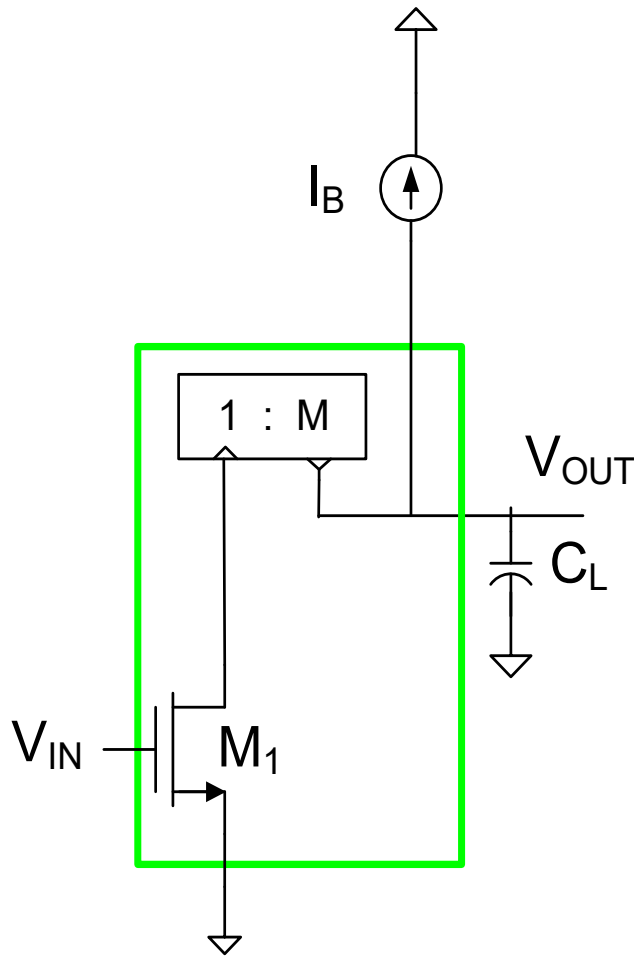

Consider this quarter circuit

$$g_{MQC} = g_{m1} M$$

$g_m$  is increased by the mirror gain !

Folding is required to establish the correct bias current direction

Consider using the quarter circuit itself to form the op amp

Could have done this (or can do) for other quarter circuits as well

Output conductance of QC:  $g_{oQC}$  22

# $g_{mEQ}$ Gain Enhancement Strategy

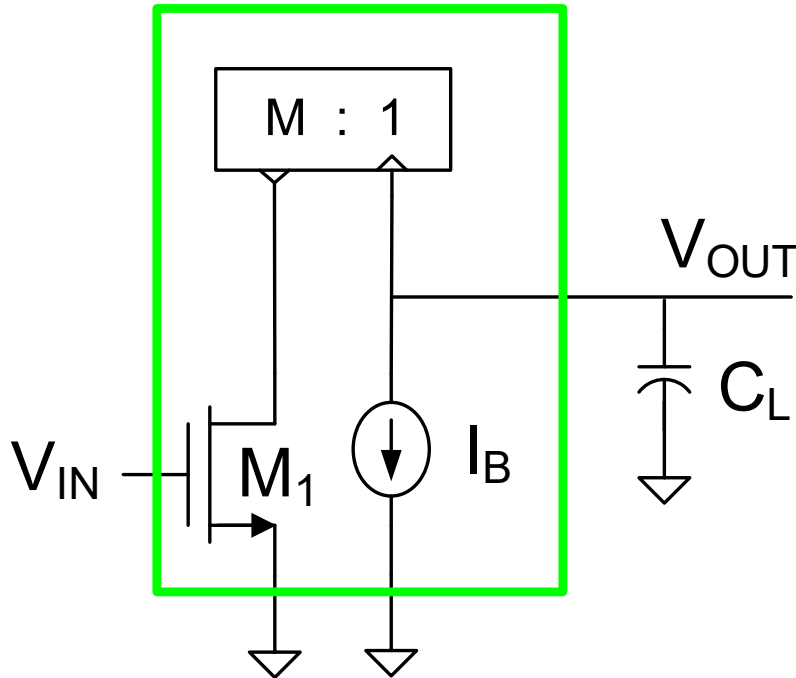

$$g_{MQC} = g_{M1}M$$

$$g_{OEQ} = g_{OQC} + g_{OI_{BB}}$$

$$A_V = \frac{-g_{m1}M}{sC_L + g_{0EQ}}$$

Redraw to absorb  $I_B$  in the quarter circuit

# $g_{mEQ}$ Gain Enhancement Strategy

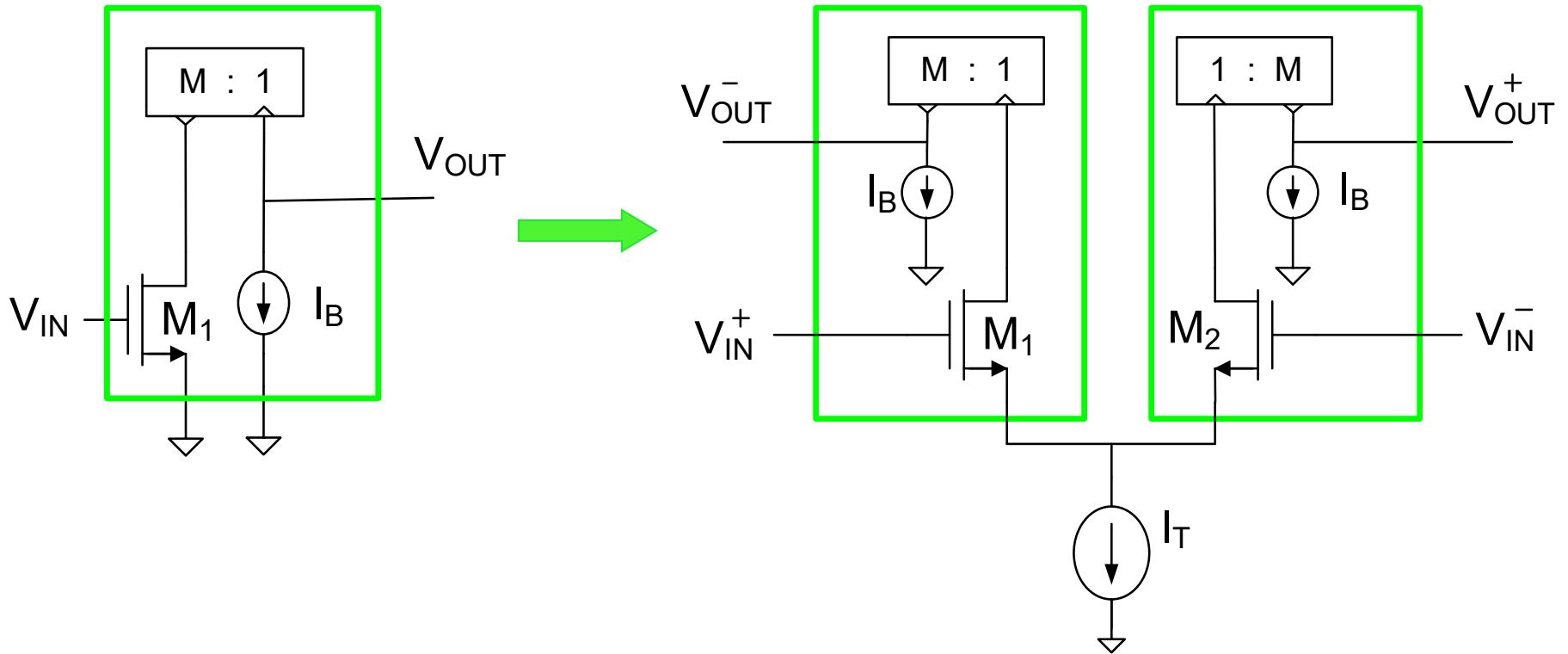

# $g_{mEQ}$ Gain Enhancement Strategy

Have we seen something very similar to this before?

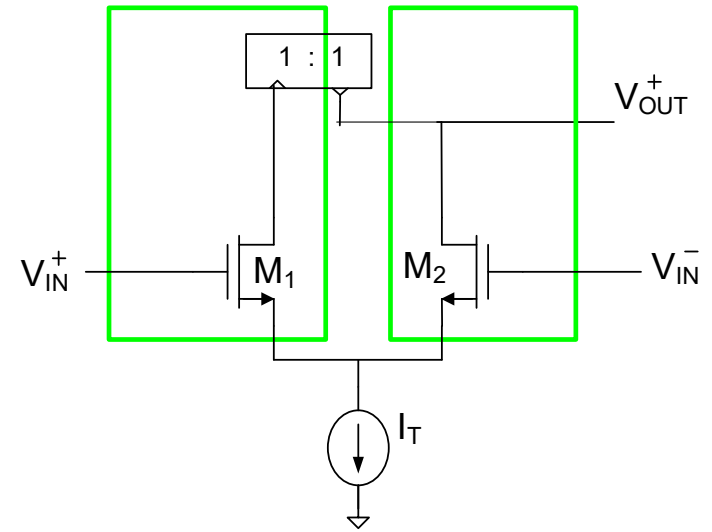
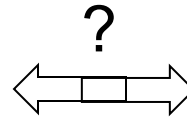
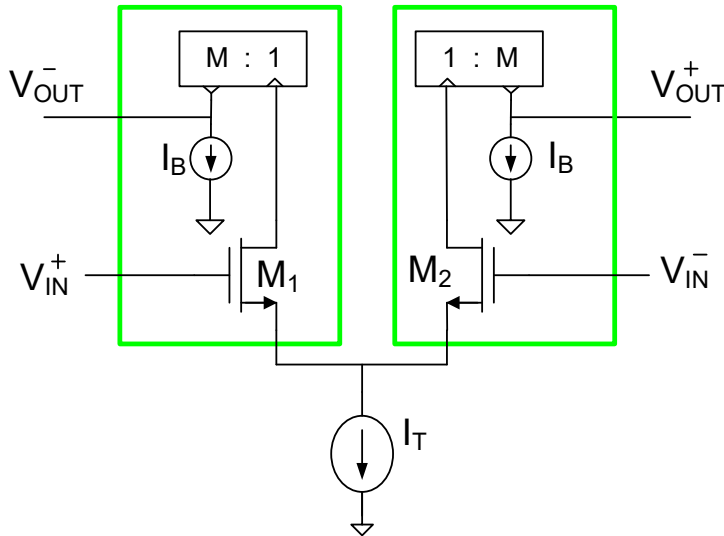

increases effective  $g_m$  by a factor of  $M$

does not sacrifice an output

doubled effective  $g_m$  (factor of  $1+M$ )

sacrificed one output

eliminates need for CMFB



# What about this?

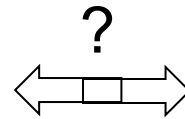
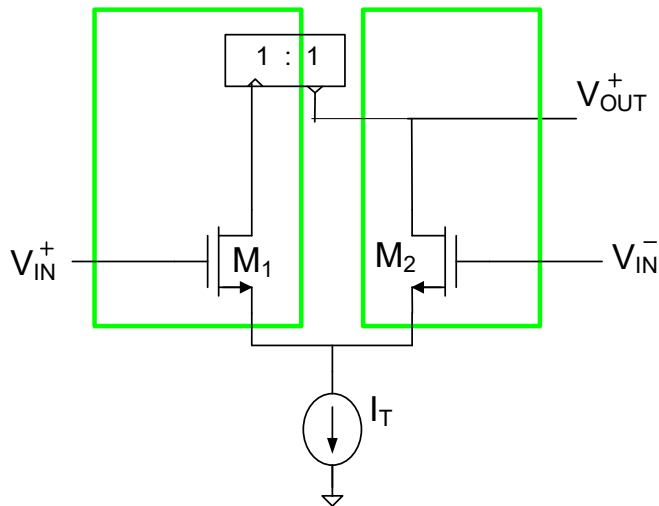
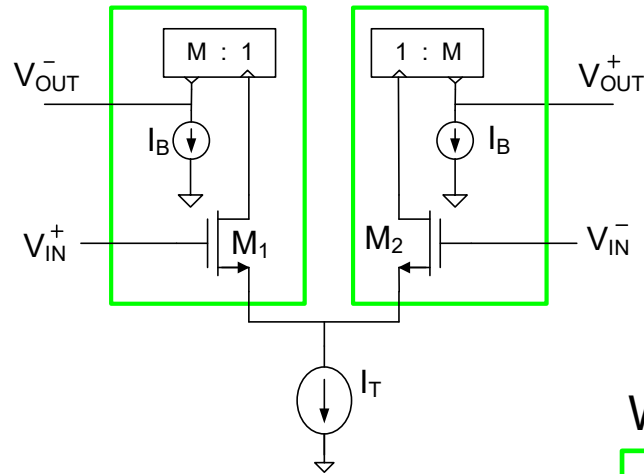

What about this circuit?

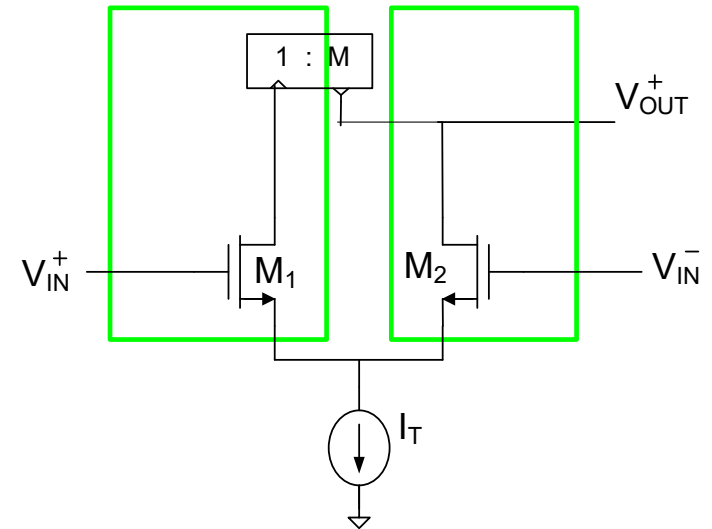

Increases effective  $g_m$  by  $1+M$   
 Leave this circuit to HW problem

# What about this?

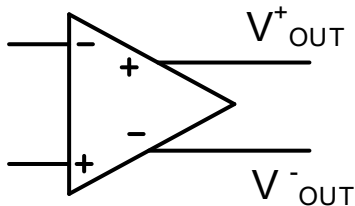
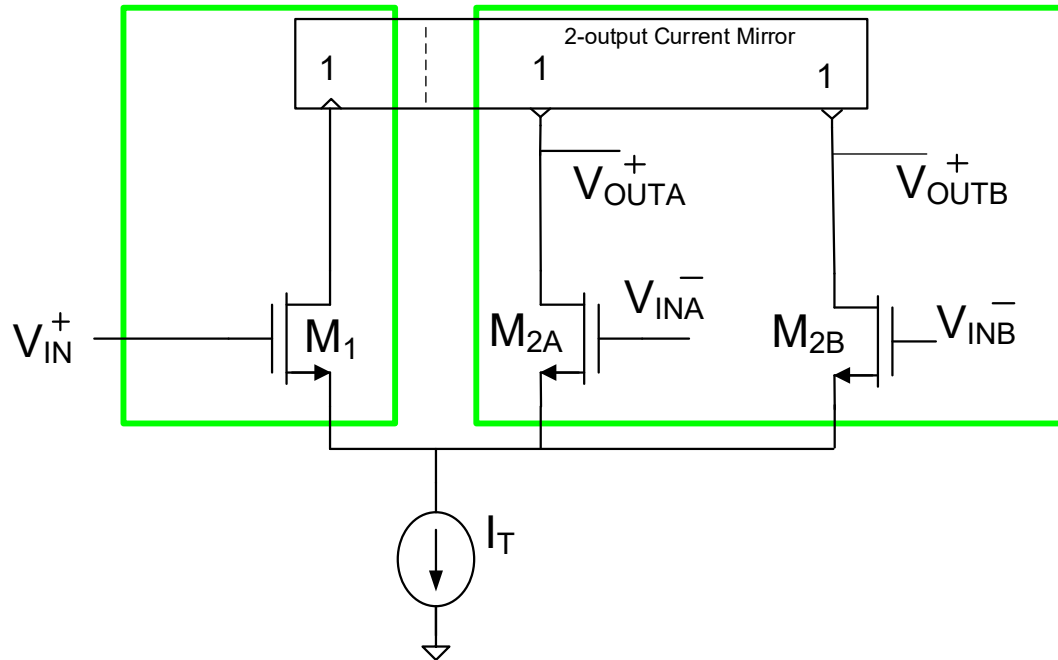

Not Quite

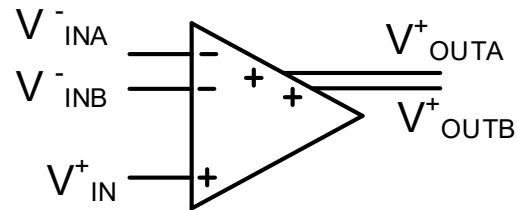

New Device

Interesting properties – is it useful?

# Current Mirror Op Amps

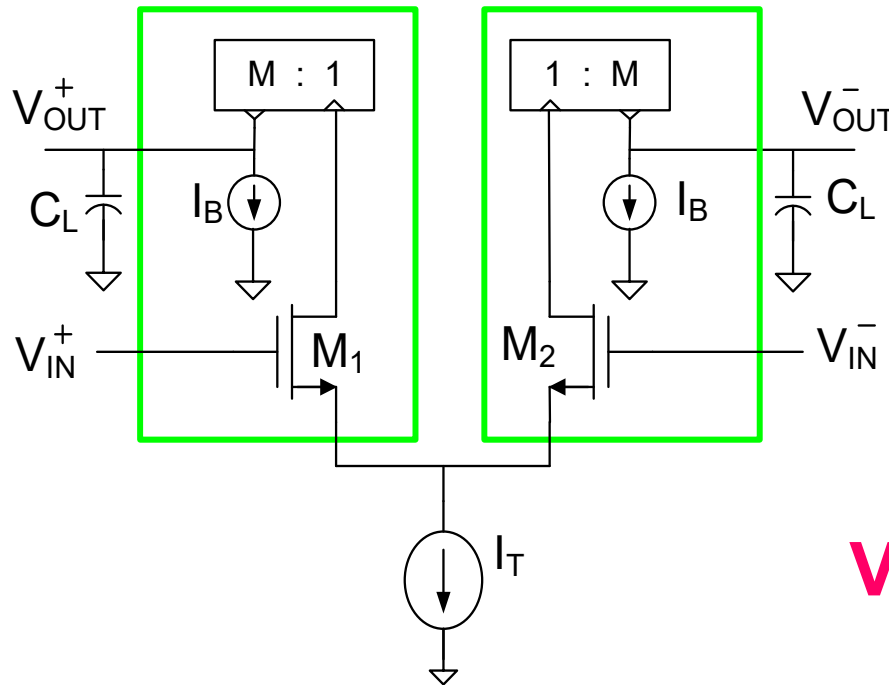

$$A_{Vd} = \frac{V_{OUT}^-}{V_{IN}^+ - V_{IN}^-}$$

$$A_{Vd} = \frac{-\frac{g_{m1}}{2} M}{sC_L + g_{OEQ}}$$

**Very Simple Structure!**

Premise: Transconductance gain increased by mirror gain M

$$g_{mEQ} = M \frac{g_{m1}}{2}$$

(for  $V_{IN+} = V_d/2$ )

$$g_{OEQ} = g_{O-mirror} + g_{OI_{BB}}$$

Premise: If output conductance is small, gain can be very high

$$A_{V0} = -\frac{g_{mEQ}}{g_{OEQ}}$$

Premise: GB very good as well

Still need to generate the bias current  $I_B$

$$GB = \frac{g_{mEQ}}{C_L}$$

# Current Mirror Op Amps

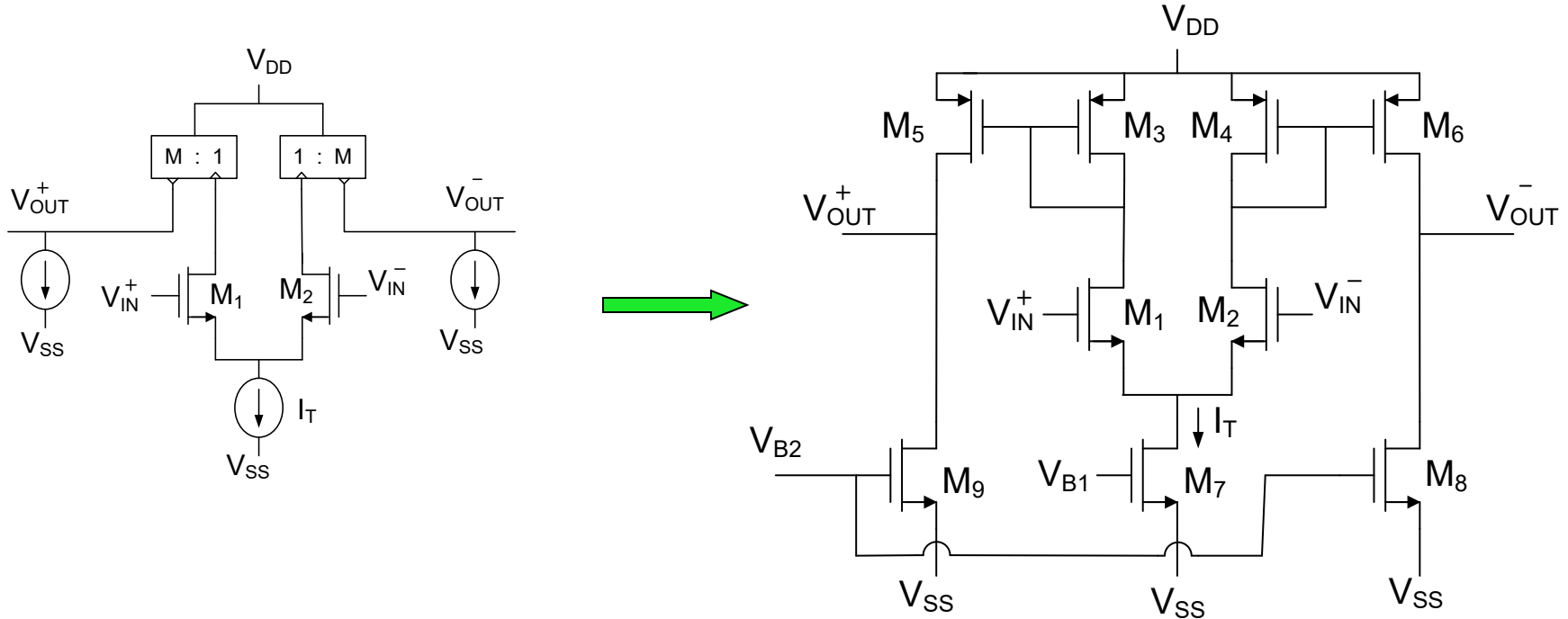

Need CMFB to establish  $V_{B2}$

**Basic Current Mirror Op Amp**

Can use higher output impedance current mirrors

Can use current mirror bias to eliminate CMFB but loose one output

# Current Mirror Op Amps

## Elimination of CMFB

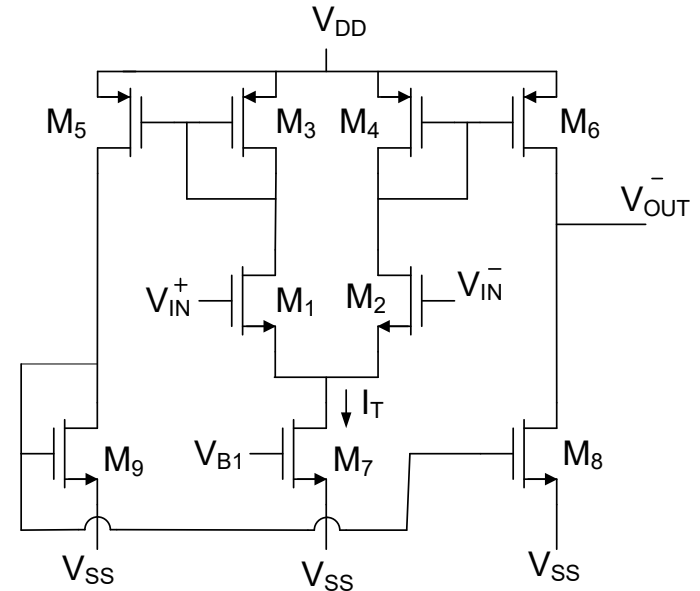
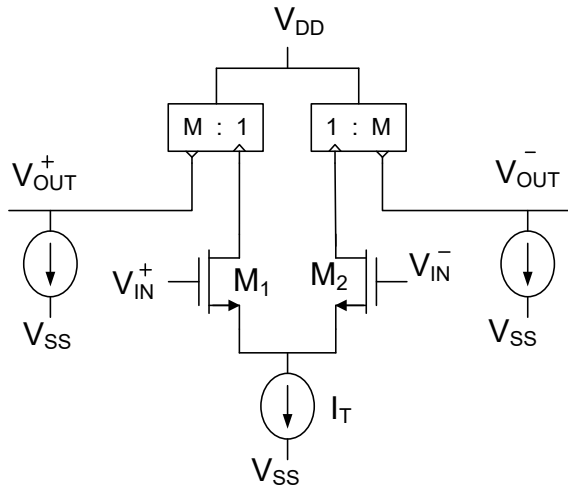

$$A_{Vd} = \frac{V_{OUT}^-}{V_d} = \frac{-\frac{g_{m1}}{2}M}{sC_L + g_{0EQ}}$$

$$A_{Vd} = \frac{-g_{m1}M}{sC_L + g_{0EQ}}$$

## Alternative Basic Current Mirror Op Amp

- Eliminated CMFB
- Doubled  $g_{meq}$
- Sacrificed one output
- Good Signal Swing at input and output
- Only 9 transistors
- Very simple circuit

Is this a real clever solution?



# Basic Current Mirror Op Amp

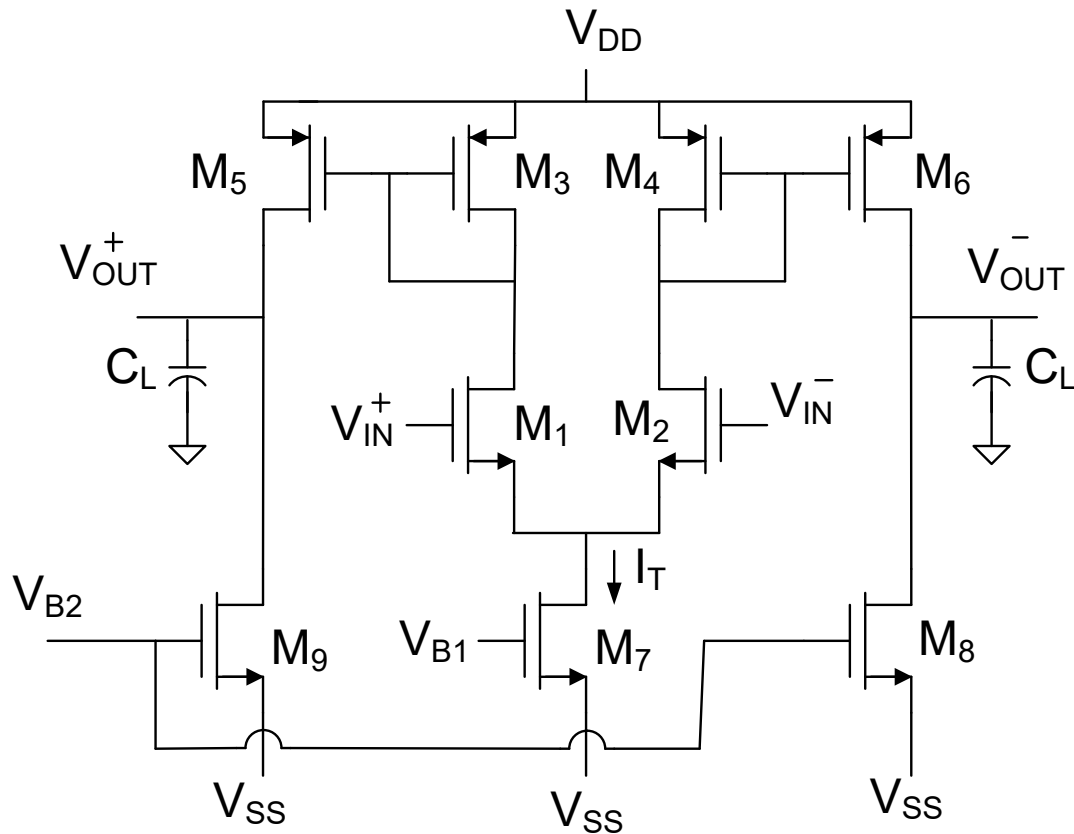

CMFB not shown

$$A_{Vd} = \frac{-g_{mEQ}}{sC_L + g_{0EQ}} = \frac{-\frac{g_{m1} M}{2}}{sC_L + g_{0EQ}}$$

$$g_{mEQ} = M \frac{g_{m1}}{2}$$

$$g_{0EQ} = g_{06} + g_{08}$$

$$GB = M \frac{g_{m1}}{2C_L}$$

$$A_{VO} = \frac{M \cdot \frac{g_{m1}}{2}}{g_{06} + g_{08}}$$

$$SR = \frac{M \cdot I_T}{2C_L}$$

# Basic Current Mirror Op Amp

- Current-Mirror Op Amp offers strategy for  $g_m$  enhancement
- Very Simple Structure
- Has applications as an OTA
- Based upon small signal analysis, performance appears to be very good !
- But – how good are the properties of the CMOA?



Is this a real clever solution?



# Seminal Work on the OTA



## **OTA Obsoletes Op Amp**

by C.F. Wheatley  
H.A. Wittlinger

From:

N.E.C. PROCEEDINGS

# Seminal Work on the OTA



## **OTA Obsoletes Op Amp**

by C.F. Wheatley  
H.A. Wittlinger

From:

1969 N.E.C. PROCEEDINGS  
December 1969

# Original OTA

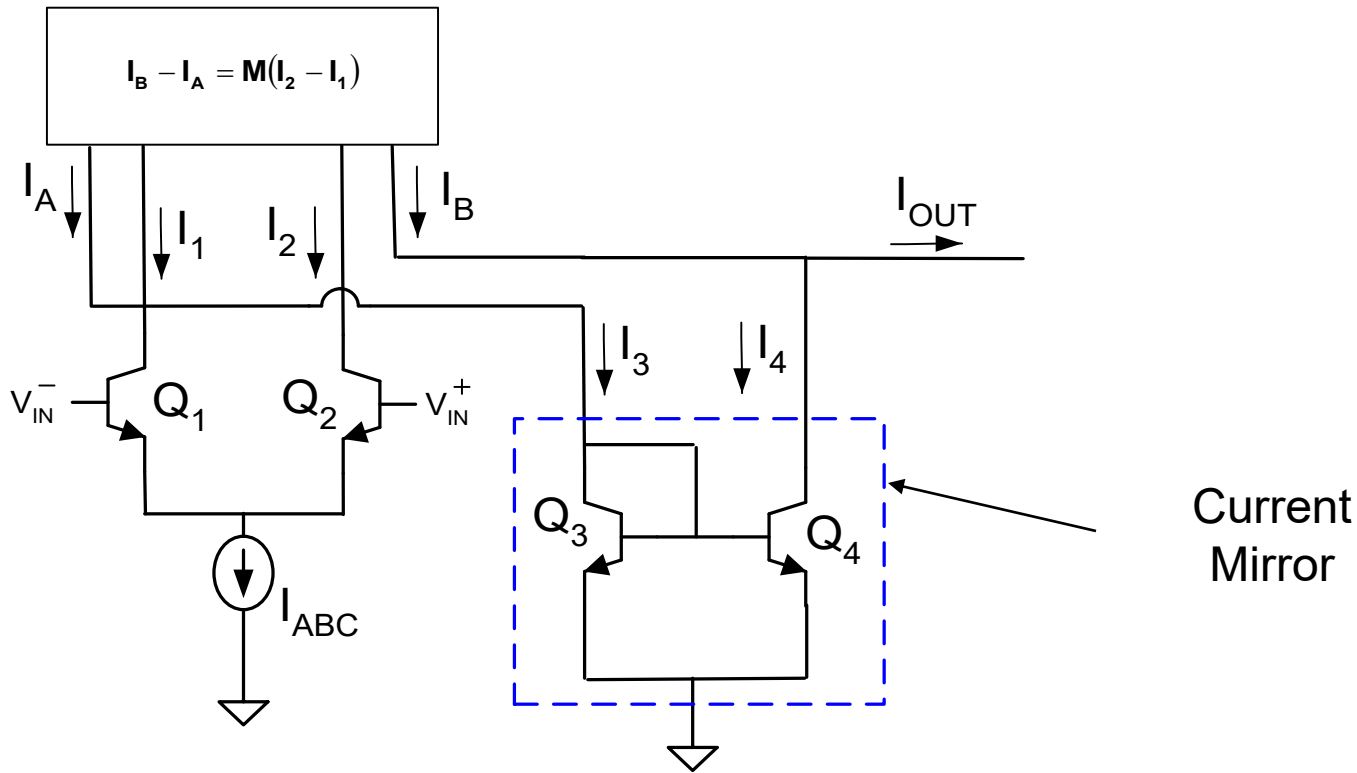

$$I_A = I_3$$

$$I_B = I_{OUT} + I_4 \quad \longrightarrow \quad I_{OUT} = M(I_B - I_A)$$

$$I_4 = I_3$$

# Original OTA

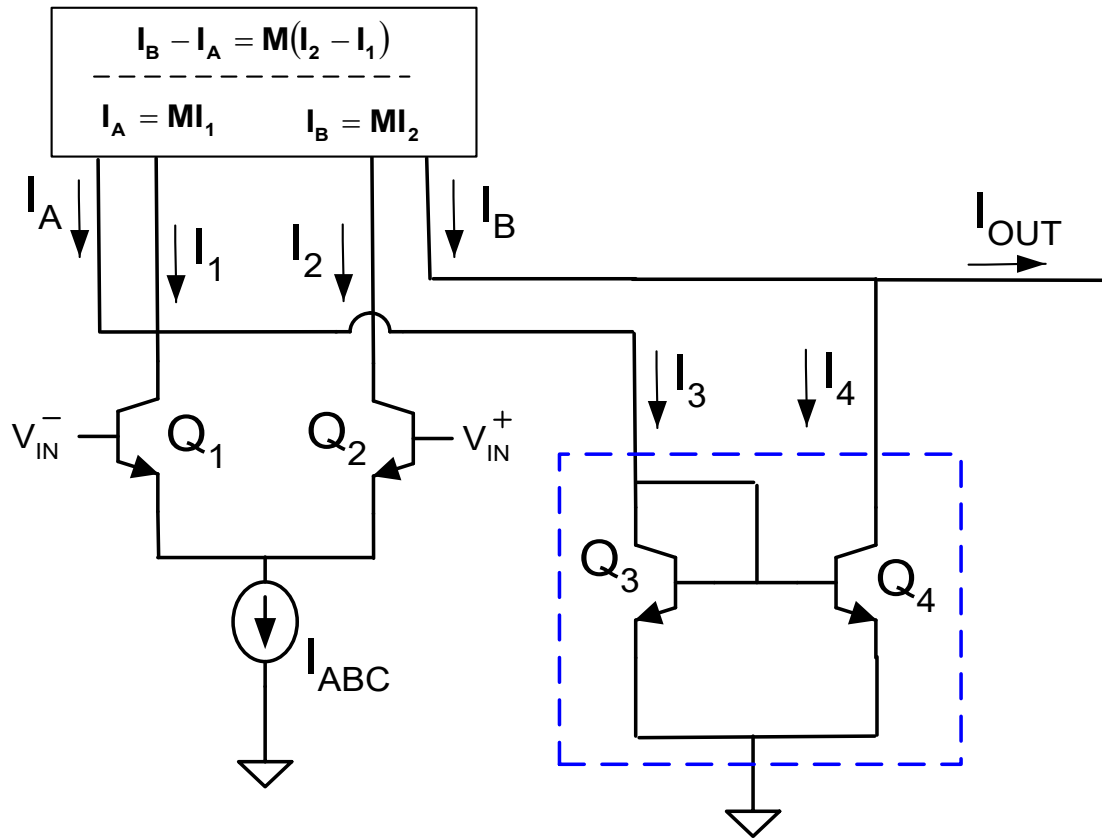

$$I_{OUT} = M(I_B - I_A)$$

# Original OTA

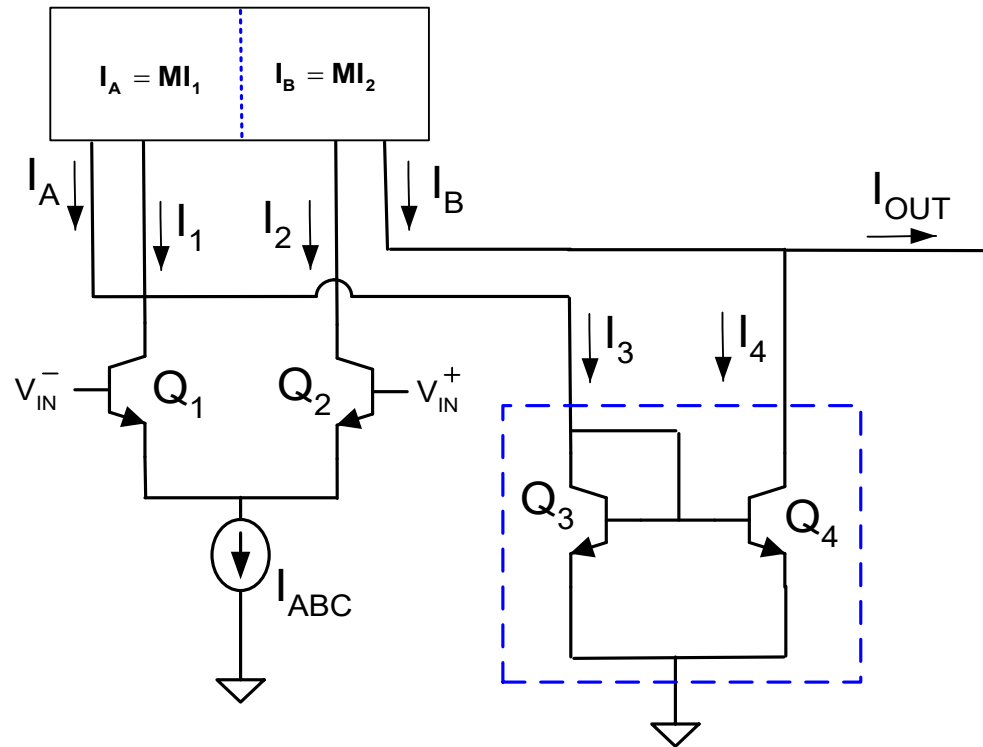

$$I_{OUT} = M(I_B - I_A)$$

# Original OTA

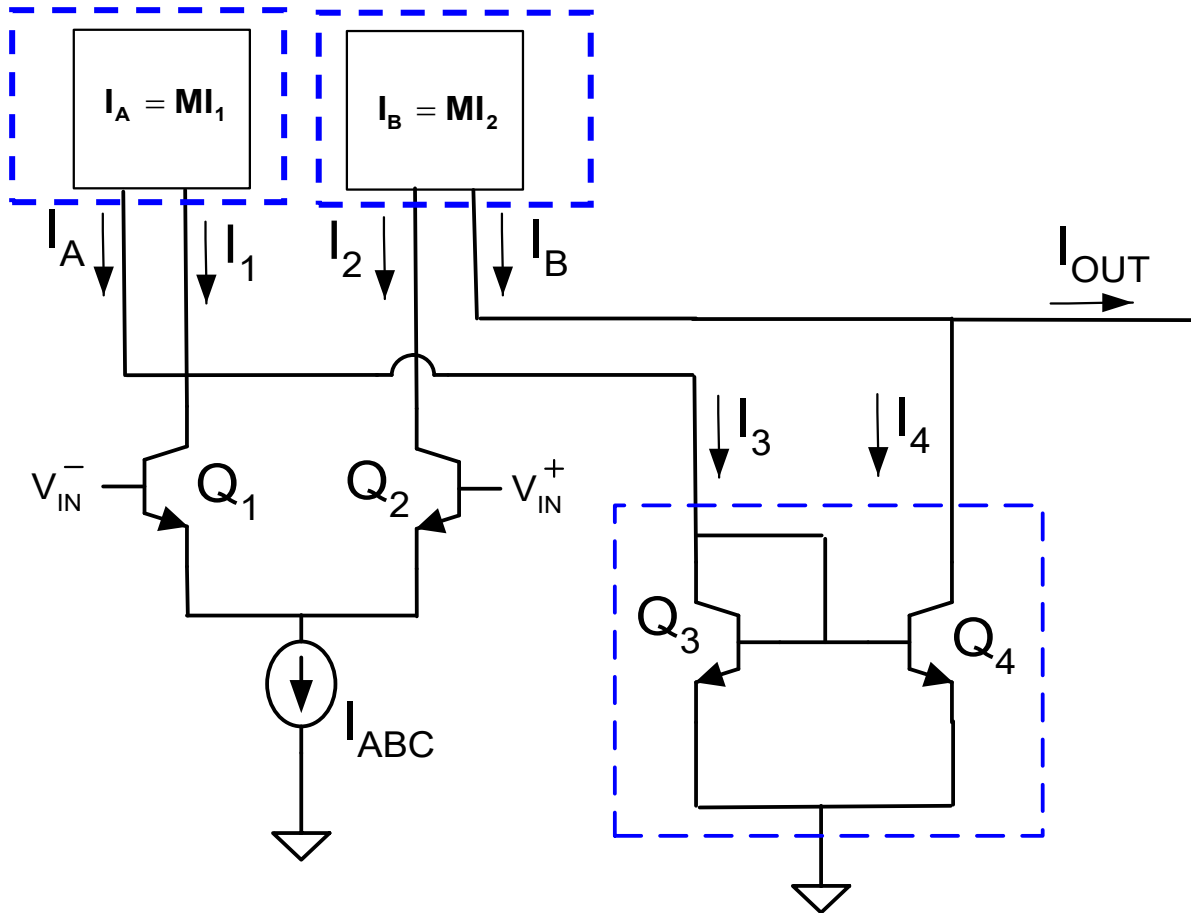

3-mirror OTA

$$I_{OUT} = M(I_B - I_A)$$

# Current Mirror Op Amp W/O CMFB

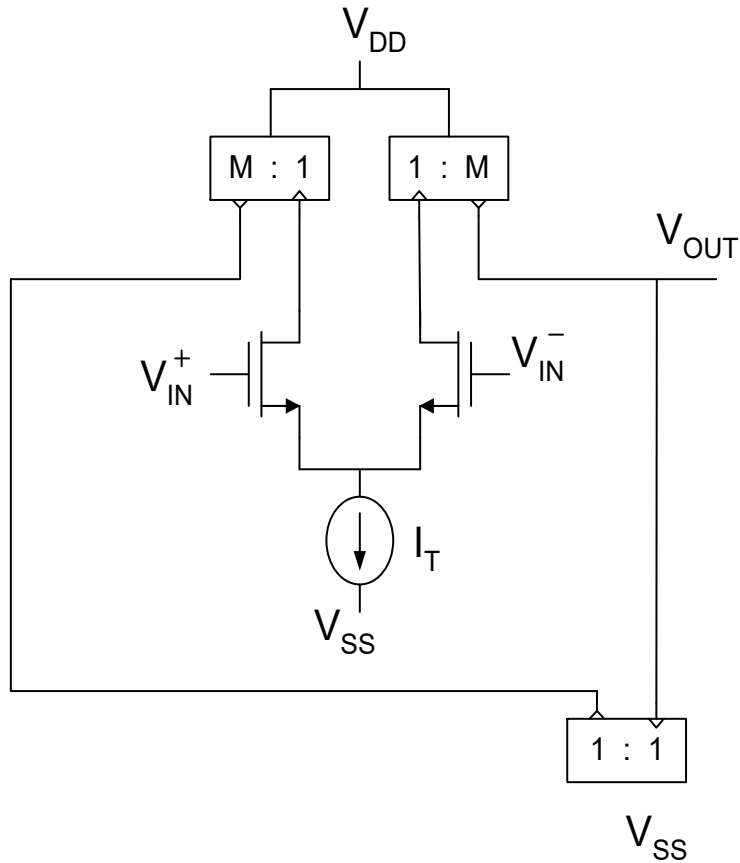

$$g_{mEQ} = Mg_{m1}$$

Often termed an OTA

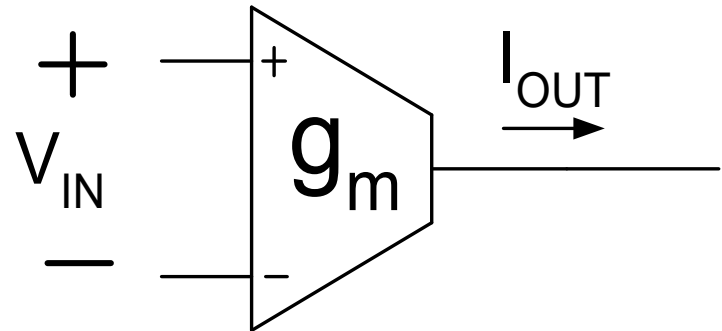

$$I_{OUT} = g_m V_{IN}$$

Introduced by Wheatley and Whitlinger in 1969

# OTA Circuits

- OTA often used open loop
- Excellent High Frequency Performance
- Gain can be made programmable with dc current
- Large or very large adjustment ranges possible

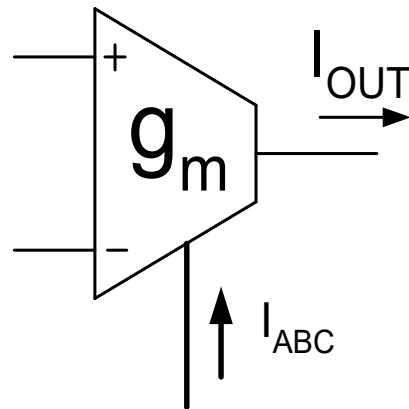

$$g_m = \begin{cases} K \cdot I_{ABC} & \text{for BJT circuits} \\ K \sqrt{I_{ABC}} & \text{for MOS circuits} \end{cases}$$

2 to 3 decades of adjustment for MOS

5 to 6 decades of adjustment for BJT



# OTA Circuits

OTA often used open loop

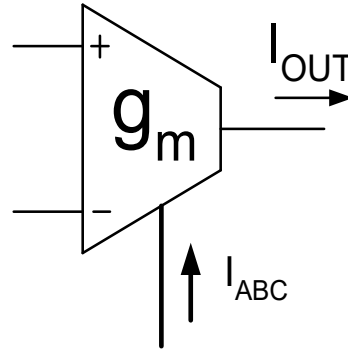

Recall: Op Amp almost never used open loop

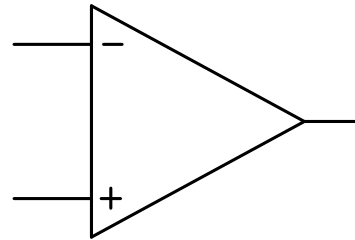

Since we just showed that the OTA is also a good high-gain op amp it seems there are conflicting statements

Challenge to students: Resolve what may appear to be conflicting statements. Will discuss this issue during the next lecture.

# OTA Applications

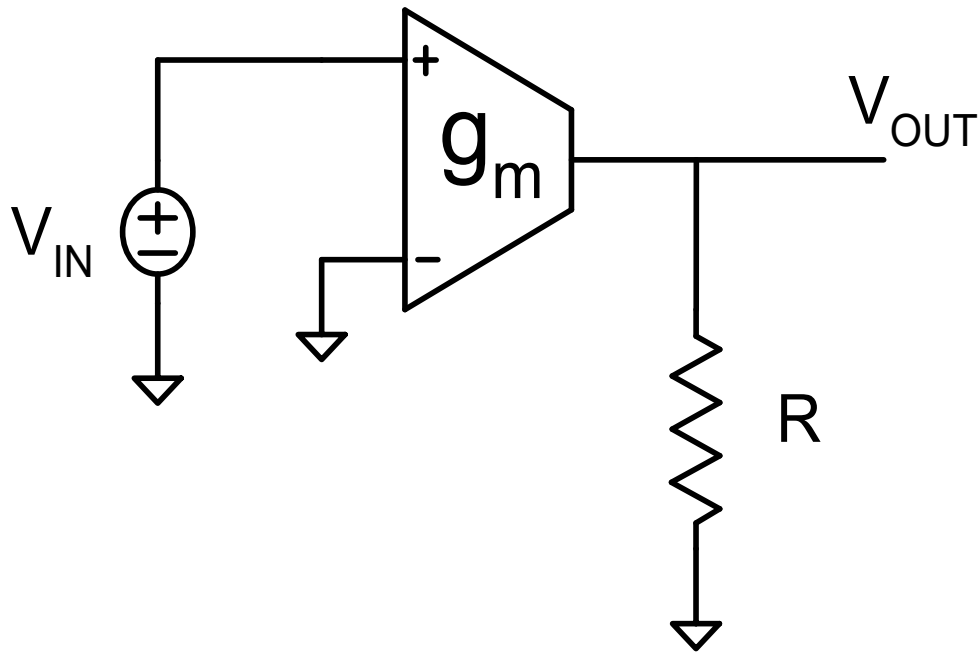

$$V_{OUT} = g_m R \bullet V_{IN}$$

$g_m$  is controllable with  $I_{ABC}$

## Voltage Controlled Amplifier

Note: Technically current-controlled, control variable not shown here and on following slides

# OTA Applications

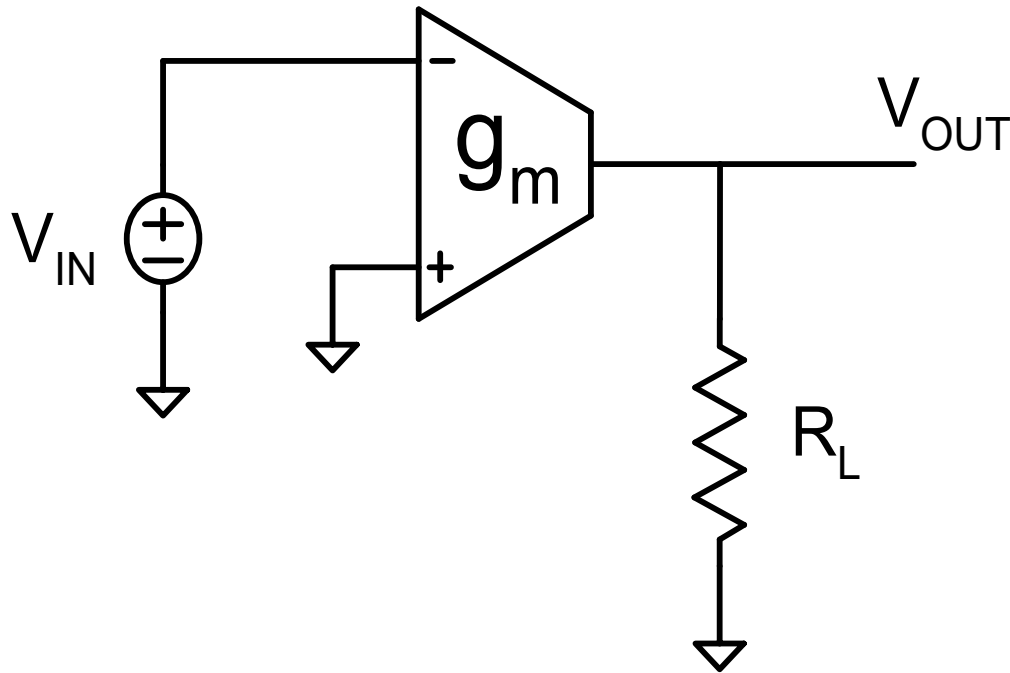

$$V_{OUT} = -g_m R \bullet V_{IN}$$

Voltage Controlled Inverting Amplifier

# OTA Applications

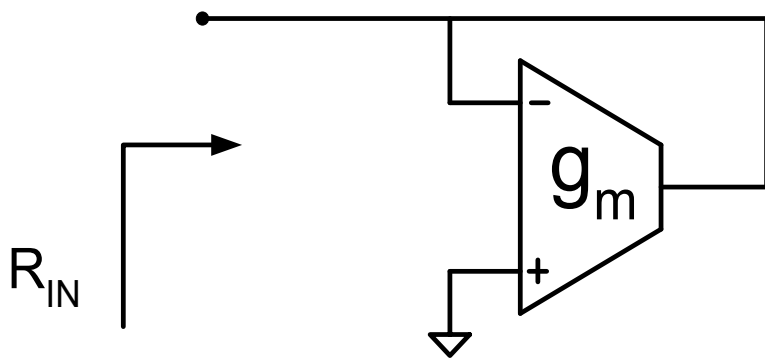

$$R_{IN} = \frac{1}{g_m}$$

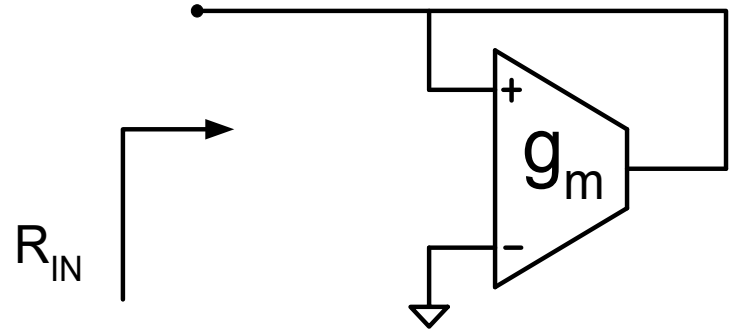

$$R_{IN} = -\frac{1}{g_m}$$

Voltage Controlled Resistances



Stay Safe and Stay Healthy !

**End of Lecture 9**